

TOOL ROOM MILLS

4-Axis CNC for Job Shops, Tool Rooms, and General Production

Featuring Automatic Tool Changer + Rigid Tapping + Versatile Programming

VKT Knee Mills



AR Bed Mills



DMC Milling Centers



VKT Knee Mill with Automatic Tool Changer

The VK-T Knee Mill is a versatile CNC milling machine for manual DRO and semi-automatic jobs, while also capable of fully automatic CNC operation, enabling traditional manual machinists or new operators to run it without any CNC training. It operates quietly with direct driven X, Y, Z, and spindle, while saving space with its compact frame. It is the ideal machine for tool rooms, prototype and repair operations, garage shops, and small parts manufacturing.

Standard Features:

- 4-Tool "Spider" Type automatic tool changer
- Peck rigid tapping and thread milling cycles
- CAT/BT 40, max 6000 RPM Spindle with Dual Winding
- Direct-drive X, Y, Z, and Spindle
- Automatic lubrication, Flood Coolant, Air Blast systems
- Table-top enclosure, splash guard, and drip pan
- MPG Handwheel with MPG Offset and MPG Run

Options:

- Dual X+Y Electronic Handwheels
- 4th Axis Rotary Table
- Power Table Height Elevator
- Tool Setting System
- Spindle Probe System

"Spider" 4T ATC

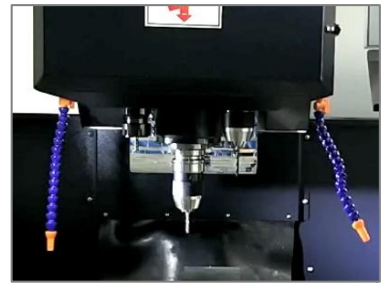

DMC Milling Center

The DMC Milling Center is a general purpose fully-enclosed CNC mill for fast and light machining. It features linear ways, a full enclosure, flood coolant, washdown, and an automatic tool changer. It is the ideal machine for tool rooms, prototype design shops, small lot, or full production operations requiring more machining speed and automation.

"Spider" 8T ATC (Standard)



Arm Type ATC (Option)



Standard Features:

- 8-Tool "Spider" Type Auto Tool Changer
- BT/CAT 40, 8000 RPM belt-drive spindle
- Peck Rigid tapping + Thread Milling
- Direct-drive XYZ axes
- Auto-lube, Flood coolant, and Washdown
- Advanced Motion Control
- MPG Handwheel with MPG Offset and MPG Run
- DRO+ Semi-Auto, Conversational + DXF, and G-Code Programming

Options:

- 24-Tool Arm Type ATC
- 12,000K RPM direct-spindle with Coolant Thru Spindle.
- Chip auger system
- 4th Axis rotary table
- Tool Setting System
- Spindle Probe System
- Dual X+Y Electronic Handwheels.

AR Bed Mill with A-Frame and Linear Rails

The AR-Series is a next generation CNC bed mill uniquely designed for precision, speed, and versatility by improving upon traditional bed mill designs.

Rigid and accurate design with wide base casting and an **A-frame vertical column**.

High precision linear roller ways and precision ball screws on all axes. Z-motor with brake eliminates the need for head counterweight.

Quill Type head with 90-degree tilt for manual / semi-auto operation, or **NC Style head** for more RPM, rigid tapping, and automatic tool changing.

CE / UKCA safety guard option.

Large 13.7", 350mm wide table with five 16mm T-slots, greatly increasing the workspace.

Wide rail spacing maintains rigidity and accuracy across the entire work envelope.

Direct-coupled servo motors with high-resolution absolute encoders accurately maintains axes positions, removing the need to home the machine when powering on.

Dual electronic handwheels for X, Y, in addition to standard MPG enables fine and effortless manual control of each axis.

AR Bed Mill Quill and NC Head Options

The AR-Series can be equipped with a Quill Head or NC Head.

QUILL HEAD OPTION

The ideal mill for manual and semi-auto ops, such as job shops, prototyping, or tool rooms, featuring:

- **5 HP (AR-1) or 7.5 HP (AR-3) Spindle up to 5000 RPM with High/Low Gear.**
- **Manual Quill with linear encoder option, up to 127mm (5") of travel, mounted on CNC controlled z-axis.**



NC + ATC HEAD OPTION

The standard bed type milling center for general purpose machining, featuring:

- **10 HP Spindle up to 8000 RPM.**
- **16-Tool Carousel-Type Tool Changer.**
- **Rigid Tapping and Spindle Orientation.**



The WinDelta Control system is a PC-based CNC control solution featuring advanced motion control, built-in software PLC, and a Windows-based HMI. The WinDelta CNC is designed for high-speed and high-precision machining, quick set up, easy programming, and universal compatibility. Its versatility allows seamless operation between manual DRO, semi-automatic, and full CNC operation, enabling any operator of any experience level to cross seamlessly from traditional manual machining into CNC automation. Features include:

- **Industrial Touchscreen LCD** interface for intuitive operation,
- **Advanced motion control** for high speed, high precision machining,
- **DRO + Semi-Auto Mode** bridges manual machining with automatic operation,
- **Conversational DXF Programming** with touch-based **CAD Editing** and **Import**,
- **Networked file management** enables shop-wide centralized data management,
- **Remote diagnostics and support** to quickly respond to any issue or service request,
- **Standard G/M-Code** with **G-Code Macro Programming** for universal compatibility.

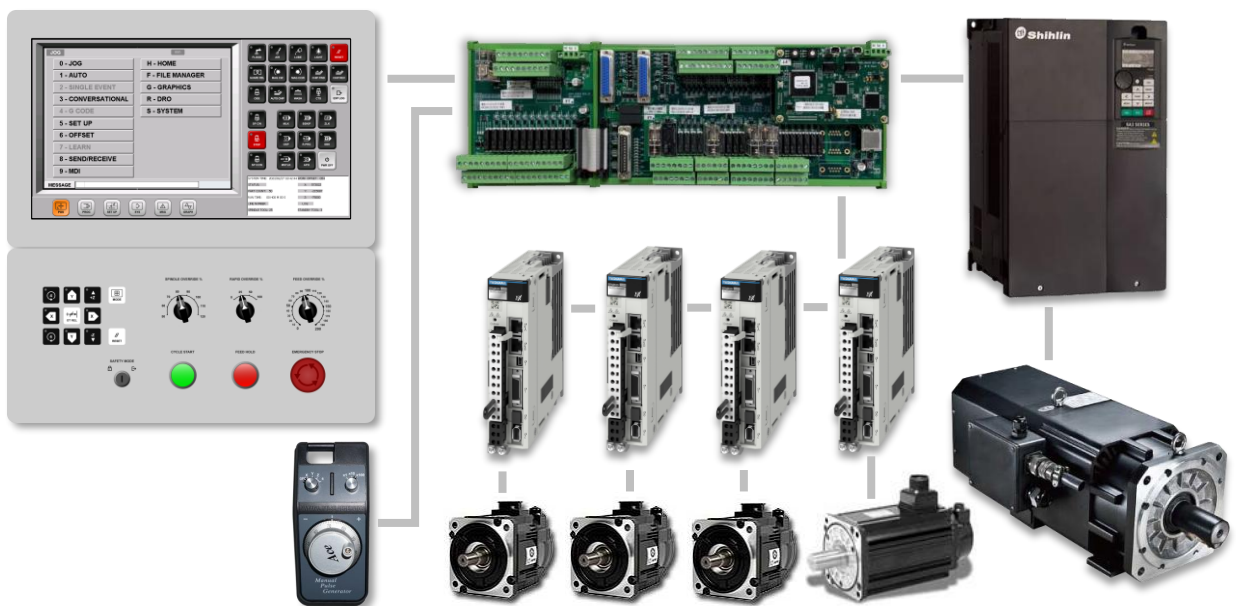

CNC Hardware Specifications

Control	• DynaPath WinDelta
Memory	• 4 GB DDR3
Storage	• 16 GB SSD
Ports	• RS232, RS422/RS485
	• RJ45 Network Port
	• 2x USB
Display	• 10.4", 12.1", 15.6", 17", 19"
	• Industrial Touchscreen LCD
	• >500 cd/m ² Luminance
Operating Panel	• MDI 1 st Panel
	• Operator's 2 nd Panel
	• USB Keyboard + Mouse

Handwheel	• Remote Jog Unit (MPG)
	• 2x Electronic Handwheels (*Option)
Axis Control	• EtherCAT or Yaskawa M-III Digital I/F
	• Max Simultaneous 4-Axis Milling
	• Dynamic 10,000-Block Look Ahead
	• 1ms Servo Update Rate
Standard I/O	• 32 DI/20 DO, 2DA/ENC/Pulse, 1 MPG
Expansion I/O	• 8 DI/18 DO
Power Input	• 24 VDC 6 A

Path Smoothing algorithms provide precision control and curvature control. The result is the optimal tool path for speed and precision.

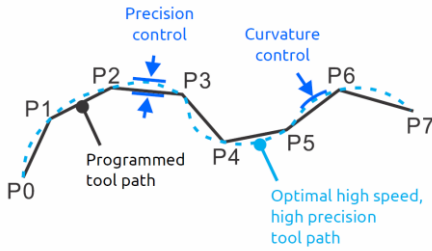

Look Ahead anticipates upcoming programmed motion commands and plans the optimal trajectory dynamically in real time.

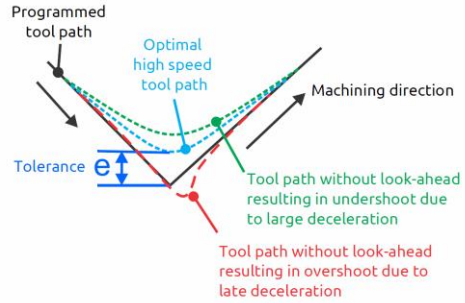

Smart Interpolation ensures machining accuracy by performing acceleration and deceleration before path interpolation.

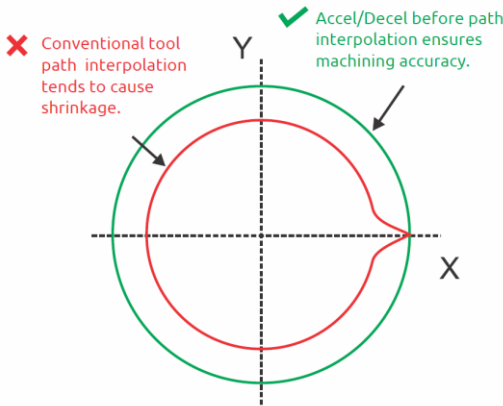

Jerk Reduction is performed by using trapezoidal or S-curve acceleration and deceleration, allowing smoother motion, higher machining speeds, and helps protect against machine wear.

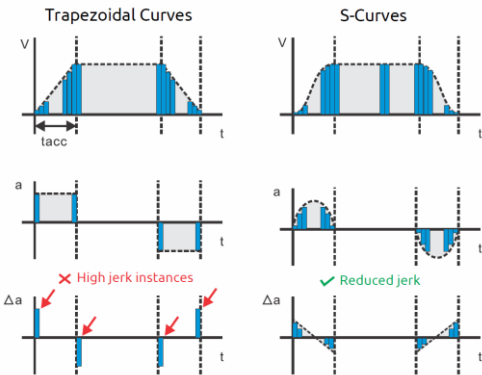

Without Feed Forward and Friction Compensation

XY and Z axes motion accuracy is prone to in correctable position errors, as demonstrated in the following plots on a circular tool path of 28.3mm diameter, at 8 m/min feed rate. In this case the final trajectory has a maximum position error exceeding 20 μm and more than 6 μm reversal spikes are presented.

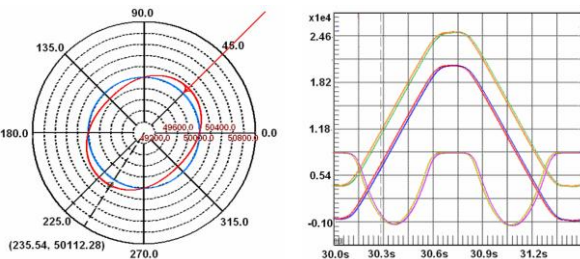

With Feed Forward and Friction Compensation

XY and Z axes motion accuracy is greatly increased, as demonstrated in the following plots on a circular tool path of 28.3 mm diameter, at 8 m/min feed rate. The final trajectory has a maximum position error within 5 μm and the reversal spikes are less than 2 μm .

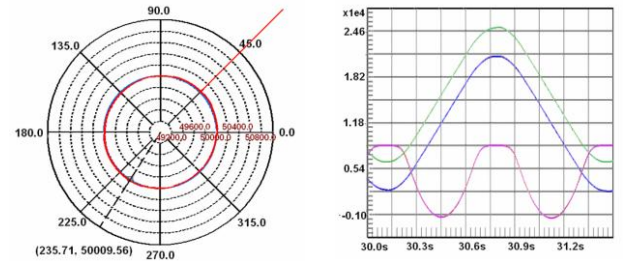

WinDelta® CNC is the most versatile control for all your many operations:

DRO + Semi-Auto + Conversational Programming + G-Code

DRO + SEMI-AUTO OPERATION

For quick and simple jobs or work requiring the skilled hands of an experienced machinist, **DRO+ Semi-Auto** offers operators the ability to manually use **electronic handwheels mixed with semi-automatic operations** to quickly machine a part.



CONVERSATIONAL DXF PROGRAMMING

For general parts and jobs, the **Conversational Editor with DXF Import** enables any operator to **open and edit CAD drawings** then import geometry as **Conversational Events** to generate part programs without writing G-Code.

STANDARD G-CODE

For those with CAD/CAM, simply post-process to standard **ISO/EIA G-Code**, then send the program via **USB or FTP networked file transfer** to the control. Advanced **G-Code Macro Programming** is also fully supported.

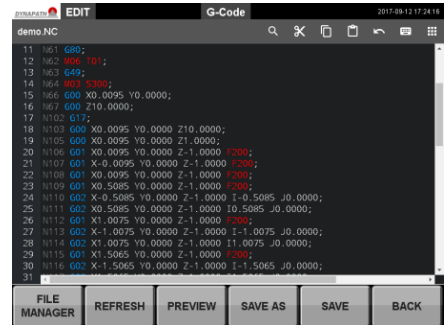
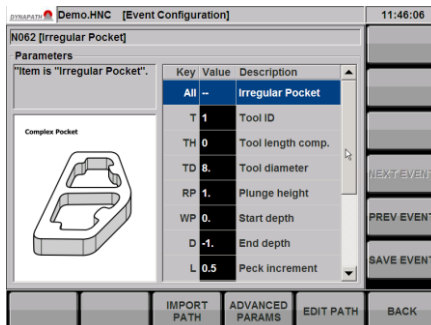
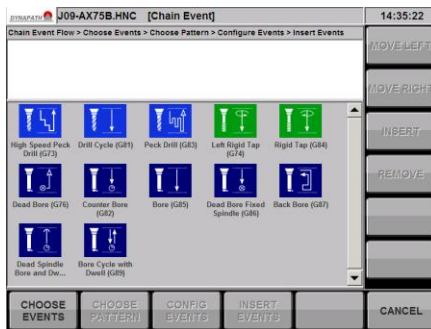
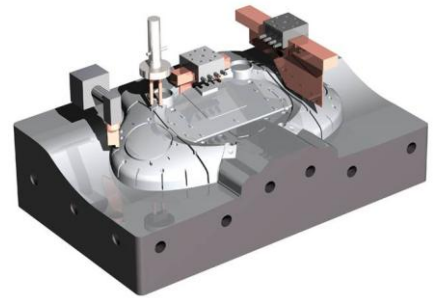

Easy Manual Operation with Enhanced CNC Productivity

DRO+ Mode for Accurate and Efficient Manual Operation

DynaPath DRO + Semi-Auto Operation

Simple and quick single-op type jobs can be performed without requiring the need for workpiece setup, tool setup, or writing a program using the **DRO+ Semi-Auto** mode. This special operation mode enables any operator of any experience level the ability to intuitively operate between **manual JOG, MPG, or Semi-Auto modes using the jog buttons and electronic handwheels** while calling **Semi-Auto Events** to quickly and accurately machine a part.



Precise and Accurate operation can be performed using the electronic handwheels with **precision up to 0.0001" or 0.001 microns** by leveraging the **high-resolution fully-closed loop CNC motion control**. Additionally, the servo motors are equipped with absolute encoders, so positions are always accurately remembered without having to re-reference the machine.

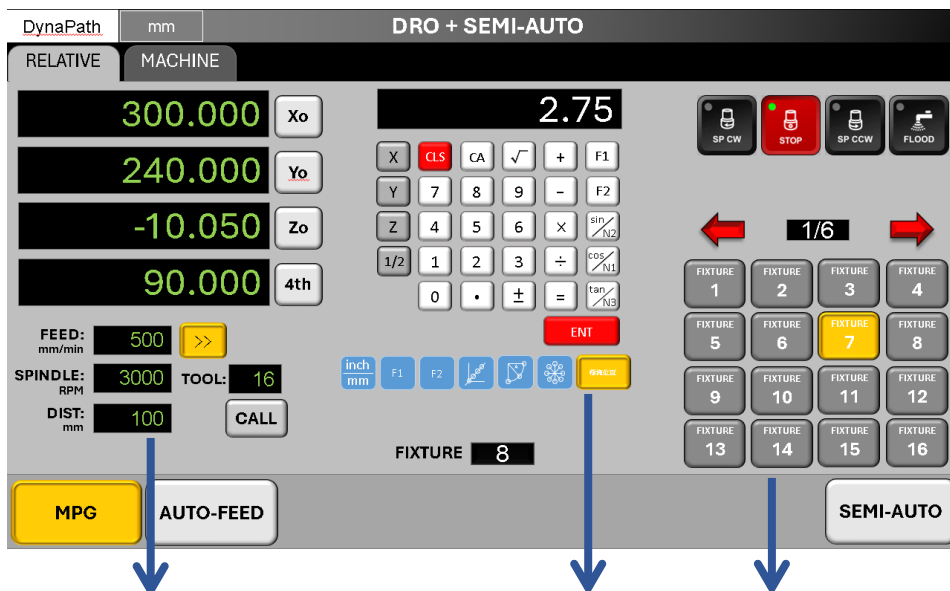

Feed Axis allows moving one or multiple axes with the jog buttons, to quickly and accurately feed at a set RPM and feed rate, to perform precise machining along a line.

Calculation Assist functions feature a standard calculator with additional geometric assist functions for performing **machining calculations, center finding, location setting**, and much more.

Store and Recall Offset locations to display coordinates with respect to a defined part zero location that was set to specific fixtures positions, stock sizes, or features on commonly machined parts.

Semi-Automatic Operation with Enhanced CNC Functionality

Semi-Auto Machining for Quick, Single Op Machining

Standard Shape Templates allows defining shapes such as rectangles, circles, ellipse, polygons, and slots by setting a just few parameters.

Intuitive Path Editor allows input of point-to-point geometry to describe a path comprising of lines and arcs for machining.

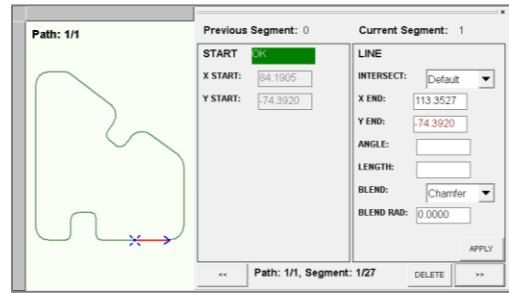
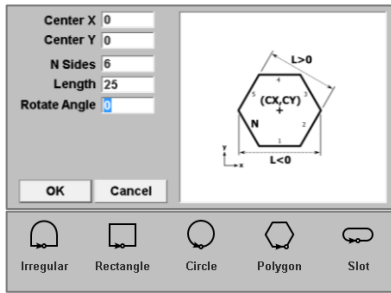

Semi-Auto Events includes standard milling cycles such as **Frames, Circles, Polygons, and Face milling events**. For hole-making, there are events such as **Drill, Bore, Tap, PCD bolt hole pattern, and line hole arrays**. The operation is quick and simple:

1. Select the machining event and geometry to perform.

2. Set parameters such as depths, feeds, and speeds.

3. Preview and run the machining operation.

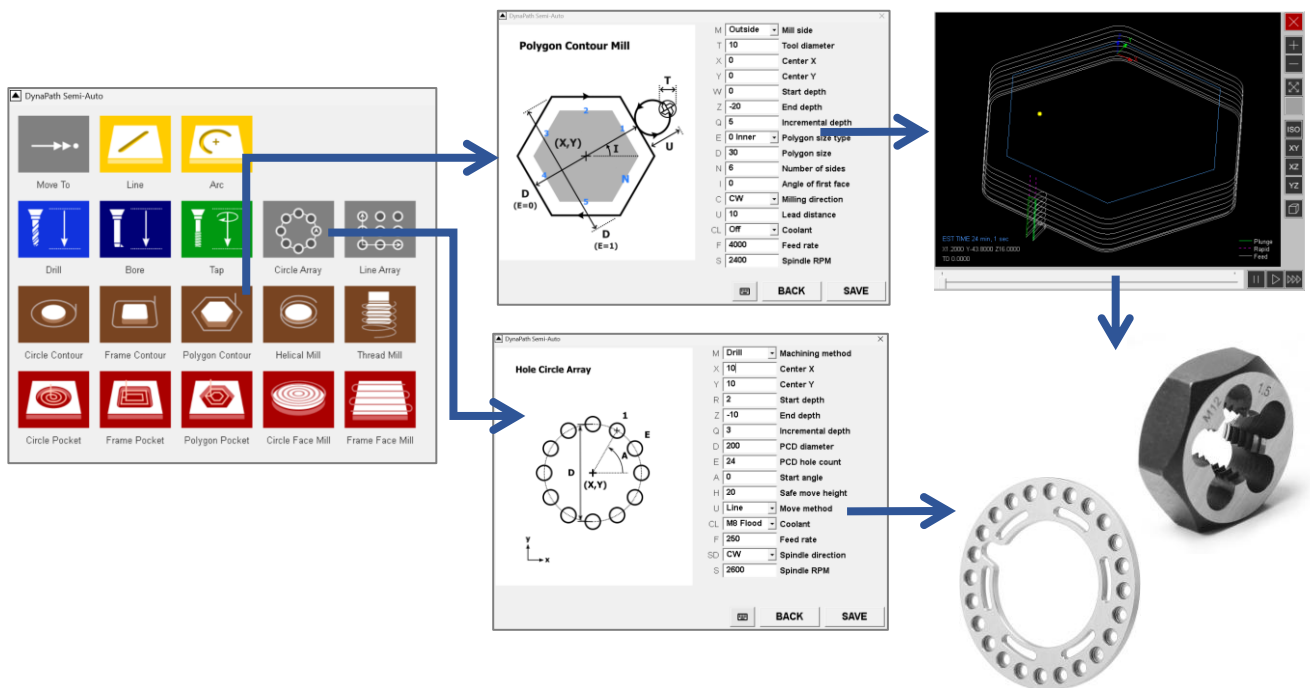

DynaPath WinDelta® Programming

Conversational Programming + DXF Import + G-Code Editing

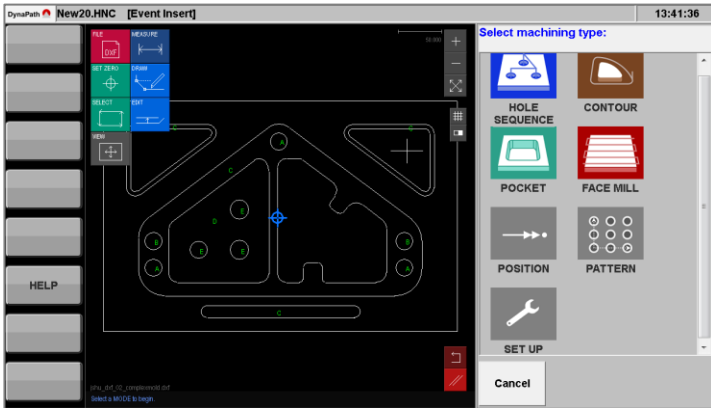

Conversational Multi-Window Event-Based Programming allows creating part programs by choosing machining events, setting its geometry, and configuring its parameters, without having to write G-Code.

Built-in Milling and Hole Events include standard contour, pocket, helix, thread mill, taper, engrave, pattern, drill, bore, tap, and many other events.

DXF Import and CAD Editing allows geometric import from DXF drawings and offers CAD editing functions via the intuitive touchscreen interface, saving valuable programming time and reduces input errors.

Hole Import enables intelligent programming of holes by:

1. Defining a sequence of drill, bore, tap, or hole mill events to machine,
2. Drag select a region of holes to apply automatic geometric grouping into a table for editing,
3. Configure cutting parameters for each group of holes,
4. Save and generate a tool-optimized hole machining program.

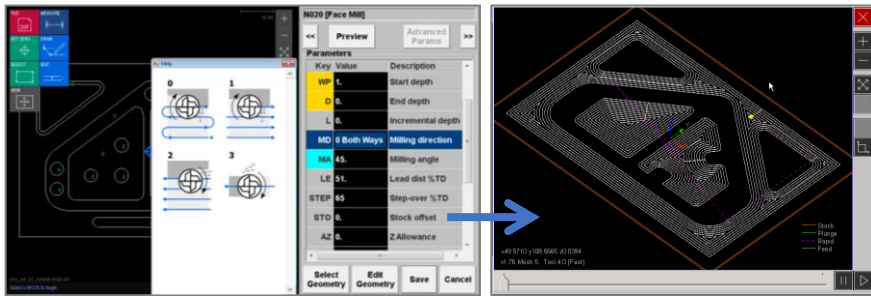
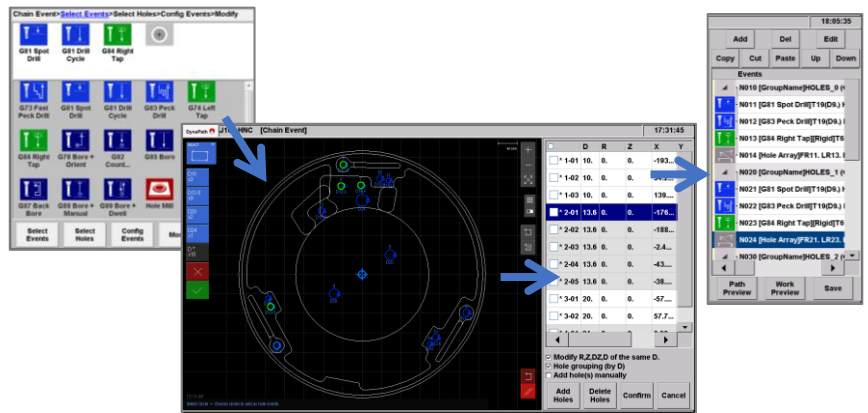

Conversational Graphics convey detailed information about event parameters using graphical illustrations to assist with data entry.

Preview Simulation allows visual inspection of generated tool paths and final dimensions.

G-Code Editor enables ISO/EIA G/M/S/T-Code editing for writing standard G-Code part programs or to fine tune CAD/CAM posts.

File Manager and Server allows USB file transfer and Networked FTP file management of all part programs and drawings on the control.

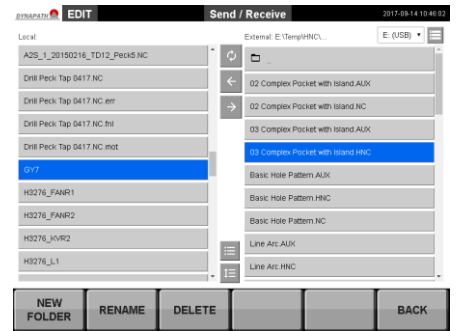
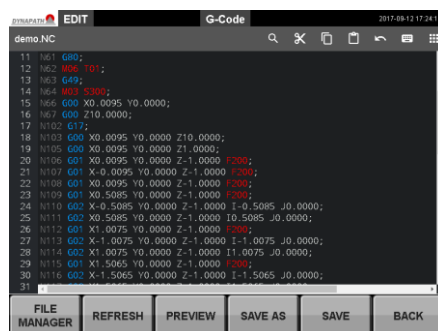

VKT KNEE MILL SPECIFICATIONS

MODEL		VKT-3T	VKT-4T
AXES	XYZ TRAVEL	700 x 310 x 270 mm (27.5" x 12.2" x 10.6")	900 x 340 x 270 mm (35.4" x 13.3" x 10.6")
	AXES TYPE X/Y/Z	Dove / Dove / Linear	Dove / Dove / Linear
	KNEE TRAVEL (Z)	350 mm (13.7")	
	SPINDLE NOSE TO TABLE	100-400 mm (3.9-15.7")	
	TOOL TO COLUMN	360 mm (14.2")	
	MOTORS X/Y/Z	0.85 / 0.85 / 0.85 kW Direct Drive	
SPINDLE	DIAMETER	120 mm (4.7")	120 mm (4.7")
	RPM	50-6000 RPM	50-6000 RPM
	DRIVE METHOD	Direct	Direct
	TAPER	BT40 / CAT40	
	MOTOR	5 HP (3.75kW) Direct Drive	
	RATED TORQUE	24 N-m (17.7 ft-lb")	
ATC	TOOL CHANGER	4-Stations	4-Stations
MOTION	MAX RAPID SPEED X/Y/Z	6000 mm/min (230 IPM)	6000 mm/min (230 IPM)
	POSITIONING ACCURACY	0.020 mm (0.000787")	
	REPEAT ACCURACY	0.010 mm (0.000394")	
TABLE	TABLE SIZE	1270 x 254 mm (50" x 10")	1470 x 320 mm (57.9" x 12.6")
	SLOTS x OFFSET x WIDTH	3 x 65 mm x 16 mm (3 x 2.916" x 5/8)	3 x 75 mm x 16 mm (3 x 2.916" x 5/8)
	MAX TABLE LOAD	220 kg (480 lbs)	
SIZE	MACHINE L x W x H	1550 x 1570 x 2200 mm (61" x 62" x 87")	1790 x 1615 x 2200 mm (71" x 64" x 87")
	FLOOR SPACE L x W x H	2250 x 2010 x 2400 mm (90" x 79" x 94")	2690 x 2010 x 2400 mm (106" x 79" x 94")
	MACHINE WEIGHT	1600 kg (3520 lbs)	1800 kg (3960 lbs)
INSTALL	COOLANT CAPACITY	40 L (10 gal)	
	AIR REQUIREMENTS	6 kg/cm ² (90 psi), 30 L/min (1 CFM)	
	POWER REQUIREMENTS	8 kVA, 3 Phase, 220V	

CONTROL SPECIFICATIONS	MACHINE FEATURES	ADDITIONAL OPTIONS
<ul style="list-style-type: none"> • 12.1"/15.6" Touchscreen LCD Display • 16 GB Program Storage • 2 USB, 1 LAN • 4-Axis Synchronous • 4th Axis Rotary Table Option • DRO Operation • ISO G-Code Motion Interpreter Core • Shop Floor Conversational Programming • DXF Drawing Import via Touch • File Send / Receive thru LAN / USB • FTP Networked File Transfer • Remote Diagnosis & Support • Remote Monitoring and Reporting • Program Retrace, MPG Run • MPG Handwheel • XY Electronic Handles Option 	<ul style="list-style-type: none"> • 4-Tool "Spider" Type Tool Changer • Peck Rigid Tapping + Thread Milling • C3 Class Precision Ball Screws • Manual Table Height Crank • Auto Lubrication System • Air + Flood Coolant System • Table-Top Enclosure • Splash Guard + Coolant Tray • Way Covers • LED Work Light • Tri-color Light Post • Tools and Toolbox • One Year Warranty on All Parts 	<ul style="list-style-type: none"> • Power Table Height Elevator • 4th Axis Rotary Table • Tool Setter System • Spindle Probe System • CE / UKCA Safety and Electrical • Dual X+Y axis Electronic Handwheels

VK-3T Dimensions

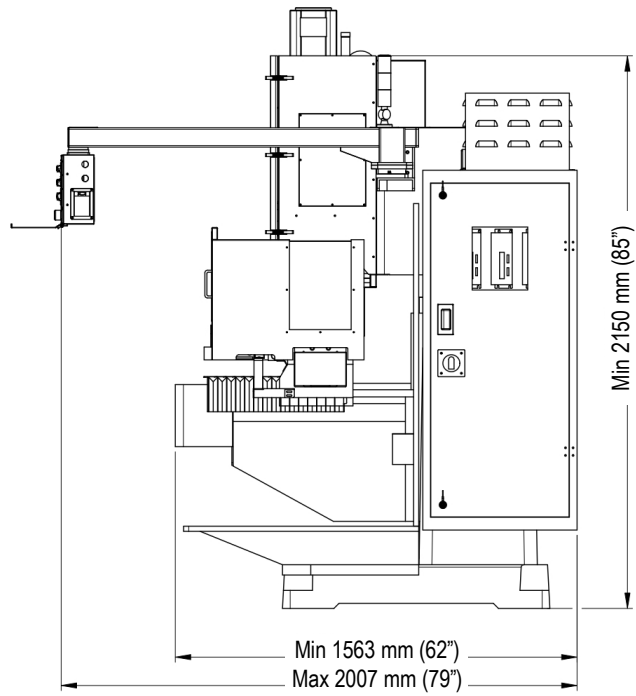
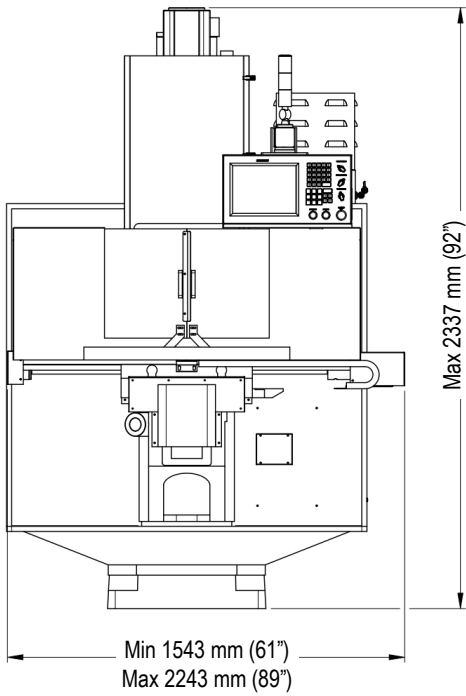

VK-4T Dimensions

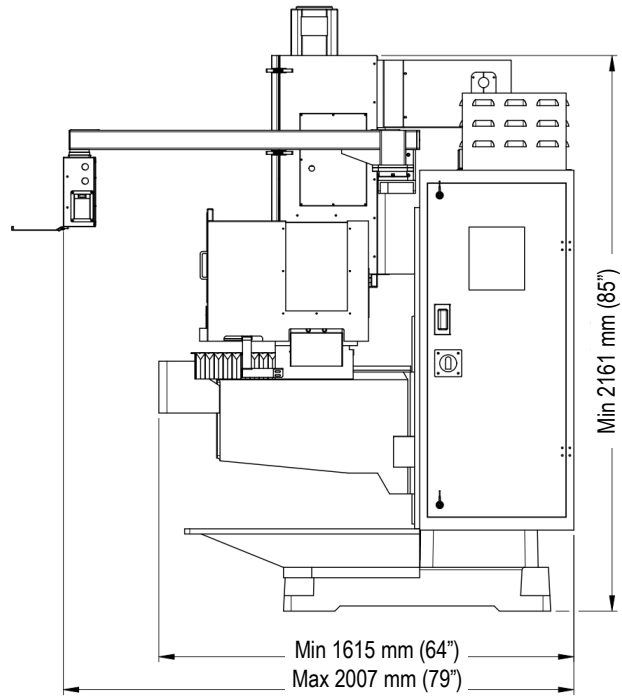
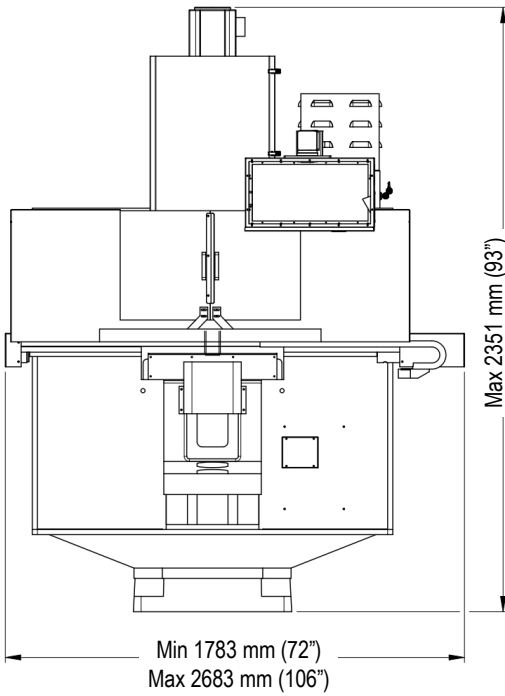

AR BED MILL SPECIFICATIONS

MODEL		AR-1	AR-3	AR-3T
AXES	X TRAVEL	710 mm (27.95")	1000 mm (39.37")	
	Y TRAVEL	400 mm (15.75")	500 mm (19.69")	
	Z TRAVEL	500 mm (19.69")	600 mm (23.62")	
	QUILL TRAVEL	127 mm (5")	127 mm (5")	
	NOSE TO TABLE, MIN	100 mm (3.94")	100 mm (3.94")	
	NOSE TO TABLE, MAX	600 mm (23.62")	710 mm (27.95")	
	TOOL TO COLUMN	483 mm (19.02")	525 mm (20.66")	
	MAX RAPID SPEED	12 m/min (472 ipm)	12 m/min (472 ipm)	
	MAX CUTTING FEED	12 m/min (472 ipm)	12 m/min (472 ipm)	
	RATED OUTPUT XYZ	0.85 / 0.85 / 1.3 kW	0.85 / 0.85 / 1.3 kW	
	MAX TORQUE XYZ	24 / 24 / 24 Nm	24 / 24 / 32 Nm	
TABLE	LENGTH	1250 mm (49.21")	1525 mm (60.04")	
	WIDTH	350 mm (13.78")	350 mm (13.78")	
	T-SLOTS/GAP/WIDTH	5 x 65 mm x 16 mm	5 x 65 mm x 16 mm	
	MAX LOAD	400 kg (880 lbs)	500 kg (1100 lbs)	
SPINDLE	TYPE	Quill Type BT40 or CAT40	Quill Type BT40 or CAT40	NC Style BT40 or CAT40
	MAX RPM	0-500 RPM Low Gear 500-5000 RPM High Gear	0-500 RPM Low Gear 500-5000 RPM High Gear	8000 RPM Belt Driven
	RATED OUTPUT	3.7 kW (5 HP)	5.5 kW (7 HP)	7.5 kW (10 HP)
	DIAMETER	100 mm (3.94")	100 mm (3.94")	120 mm (4.72")
ATC	TYPE	---	---	16-Tool Carousel
	MAX TOOL DIA	---	---	Φ90 mm (3.54")
	MAX TOOL LENGTH	---	---	300 mm (11.81")
	MAX TOOL WEIGHT	---	---	7 kg (15.4 lbs)
ACCURACY	POSITIONING ACCURACY	0.012 mm (0.00048")	0.012 mm (0.00048")	0.012 mm (0.00048")
	REPEAT ACCURACY	0.006 mm (0.00024")	0.006 mm (0.00024")	0.006 mm (0.00024")
SIZE	FLOOR SPACE, WIDTH	1600 mm (63")	1750 mm (69")	1750 mm (69")
	FLOOR SPACE, DEPTH	1860 mm (74")	1980 mm (78")	1980 mm (78")
	FLOOR SPACE, HEIGHT	2500 mm (99")	2610 mm (103")	2610 mm (103")
	WEIGHT	2150 kg (4730 lbs)	2950 kg (6490 lbs)	3150 kg (6930 lbs)
INSTALL	POWER LOAD	3 P, 220 V, 50 A, 8 KVA	3 P, 220 V, 50 A, 8 KVA	
	AIR	6 kgf/cm ² (85 PSI) 0.03 m ³ /min (1 CFM)	6 kgf/cm ² (85 PSI) 0.03 m ³ /min (1 CFM)	
	COOLANT CAPACITY	30 L (8 gal)	50 L (11 gal)	

CONTROL SPECIFICATIONS	MACHINE FEATURES	ADDITIONAL OPTIONS
<ul style="list-style-type: none"> 15.6" Touchscreen LCD Display 16 GB Program Storage 2 USB, 1 LAN Ports 4-Axis Synchronous Capable MPG Offset and MPG Run DRO + Semi-Auto Operation Standard ISO G-Code + Macro Programming Conversational Programming DXF CAD Drawing + Import via Touch File Send / Receive thru LAN / USB FTP Networked File Server Remote Diagnosis & Support Remote Monitoring and Reporting Dynamic 10,000 Block Look Ahead Program Retrace, MPG Run 	<ul style="list-style-type: none"> Auto Lubrication System Air/Flood Coolant System Thread Milling C3 Class Precision Ball Screws Table-Top Enclosure Splash Guard + Coolant Tray Way Covers LED Work Light <p>Available on NC Head:</p> <ul style="list-style-type: none"> Tri-color Light Post Rigid Tapping Spindle Orientation 	<ul style="list-style-type: none"> Power Drawbar (Quill head only) Dual X+Y axis Electronic Handwheels 4th Axis Rotary Table Tool Setter System Spindle Probe System CE / UKCA Safety and Electrical

AR-1 Dimensions

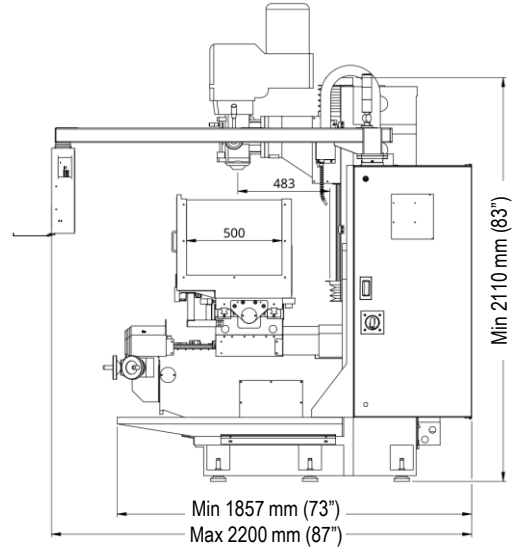
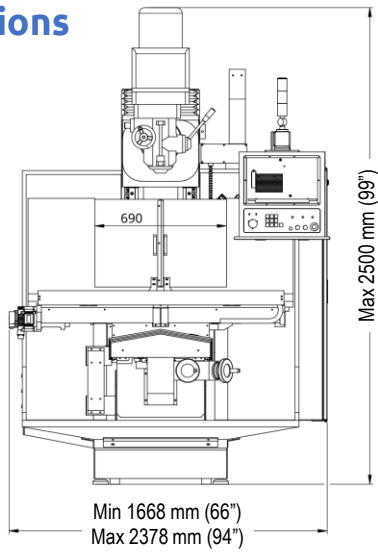

AR-3 Dimensions

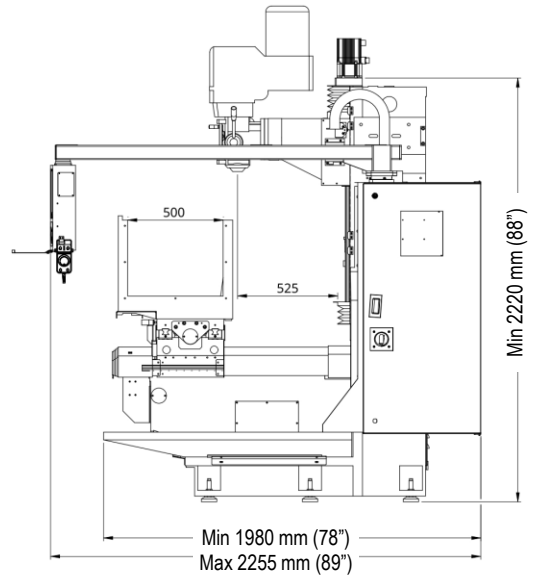
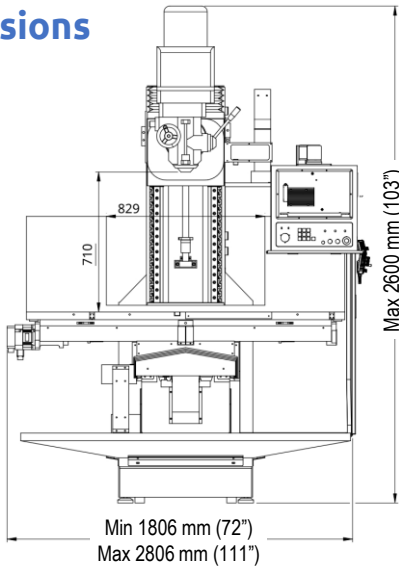

AR-3T Dimensions

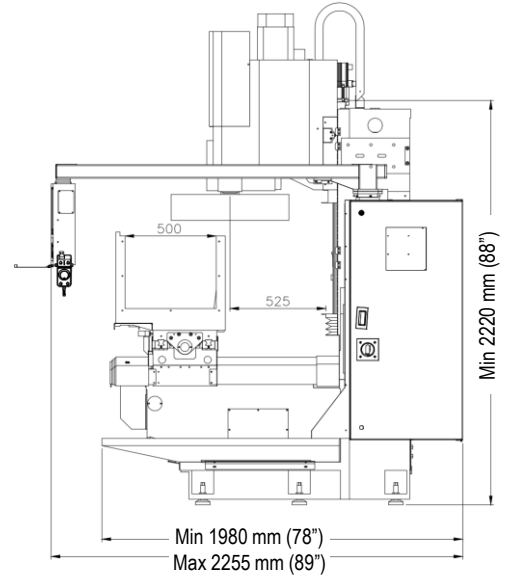
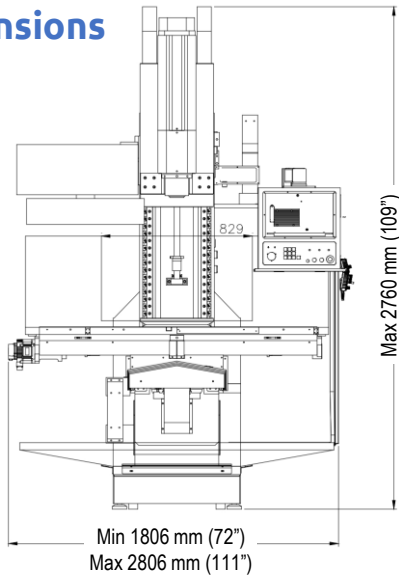

DMC MILLING CENTER SPECIFICATIONS			
MODEL		DMC-845L	DMC-845LS
AXES	XYZ TRAVEL	800 x 400 x 500 mm (31.4" x 15.7" x 19.6")	
	AXES TYPE X/Y/Z	Linear Roller / Linear Roller / Linear Roller	
	SPINDLE NOSE TO TABLE	110 - 535 mm (4.3-21.0")	
	TOOL CENTER TO COLUMN	435 mm (17.1")	
	MOTORS X/Y/Z	0.85 / 0.85 / 1.3 kW Direct Drive	
SPINDLE	DIAMETER	127 mm (5.0")	
	TAPER	BT40 / CAT40	
	RPM	50-8000 RPM	50-12,000 RPM
	TYPE	Belt Drive	Direct Drive + Thru-Spindle Coolant
	POWER	5.5 kW (7 HP)	7.5 kW (10 HP)
	MAX TORQUE	36 N-m (26 ft-lbf)	48 N-m (35 ft-lbf)
	COOLING	Air	Oil Chiller
ATC	TOOL CHANGER	8-Tool Independent Arm Tool Changer 24-Tool Arm Type Tool Changer (Option)	
	MAX TOOL DIA / WEIGHT	Ø63 mm (Ø2.4") / 5 kg (11.0 lbs)	
MOTION	MAX RAPID SPEED X/Y/Z	20 m/min (787 IPM)	
	POSITIONING ACCURACY	0.012 mm (0.00020")	
	REPEAT ACCURACY	0.006 mm (0.00012")	
TABLE	TABLE SIZE	850 x 420 mm (33.5" x 16.5")	
	SLOTS x OFFSET x WIDTH	4 x 85 mm x 18 mm (4 x 3"11 x 45/64)	
	MAX TABLE LOAD	200kg (440 lbs)	
INSTALL	FLOOR SPACE W x L x H	2200 x 2200 x 2310 mm (87" x 87" x 91")	
	SHIPPING / MACHINE WEIGHTS	3800 kg (8360 lbs) / 3050 kg (6710 lbs)	
	COOLANT CAPACITY	200 L (52 gal)	
	AIR REQUIREMENTS	6 kg/cm ² (90 psi), 200 L/min (7 CFM)	
	POWER REQUIREMENTS	15 kVA, 3 Phase, 220V	

CONTROL SPECIFICATIONS	MACHINE FEATURES	ADDITIONAL OPTIONS
<ul style="list-style-type: none"> • 15.6" Touchscreen LCD Display • 16 GB Program Storage • 2 USB, 1 LAN Ports • 4-Axis Synchronous Capable • MPG Offset and MPG Run • DRO + Semi-Auto Operation • Standard ISO G-Code + Macro Programming • Conversational Programming • DXF CAD Drawing + Import via Touch • File Send / Receive thru LAN / USB • FTP Networked File Server • Remote Diagnosis & Support • Remote Monitoring and Reporting • Dynamic 10,000 Block Look Ahead • Program Retrace, MPG Run 	<ul style="list-style-type: none"> • 8-Tool "Spider" Type Tool Changer • Peck Rigid Tapping + Thread Milling • C3 Class Precision Ball Screws • Auto Lubrication System • Full Enclosure • Flood Coolant System & Chip Recovery Tray • Washdown and Hose Gun • LED Work Light • Tri-color Light Post • Tools and Toolbox • One Year Warranty on All Parts 	<ul style="list-style-type: none"> • 24-Tool Arm Type Tool Changer • 12,000 RPM Direct Drive Spindle with Coolant Through Spindle (CTS) • 4th Axis Rotary Table • Tool Setter System • Spindle Probe System • Chip Auger System • Oil Mist Collection System • CE / UKCA Safety and Electrical

DMC-845 Dimensions

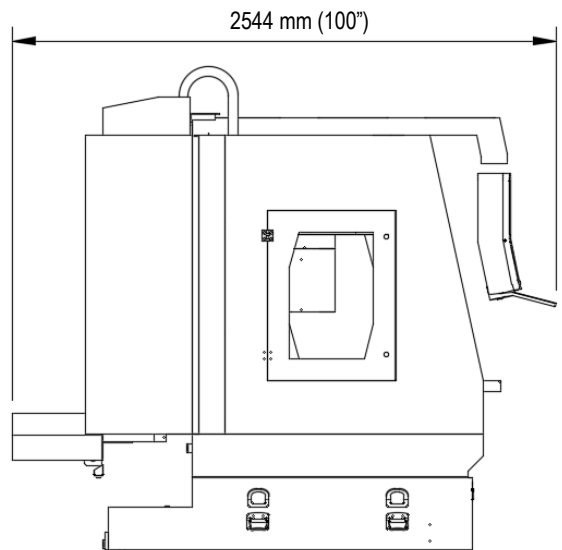
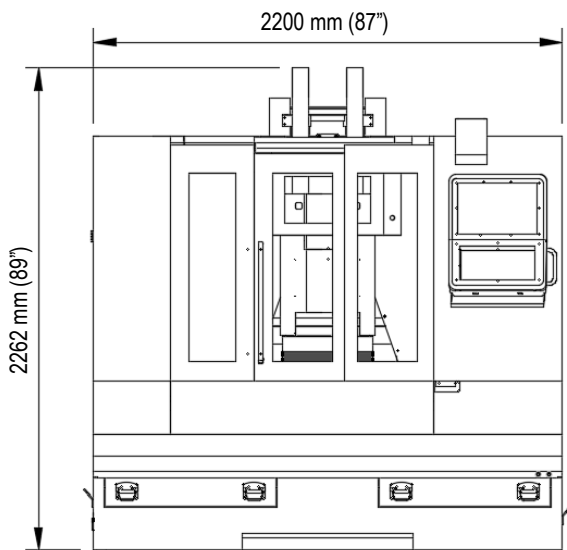
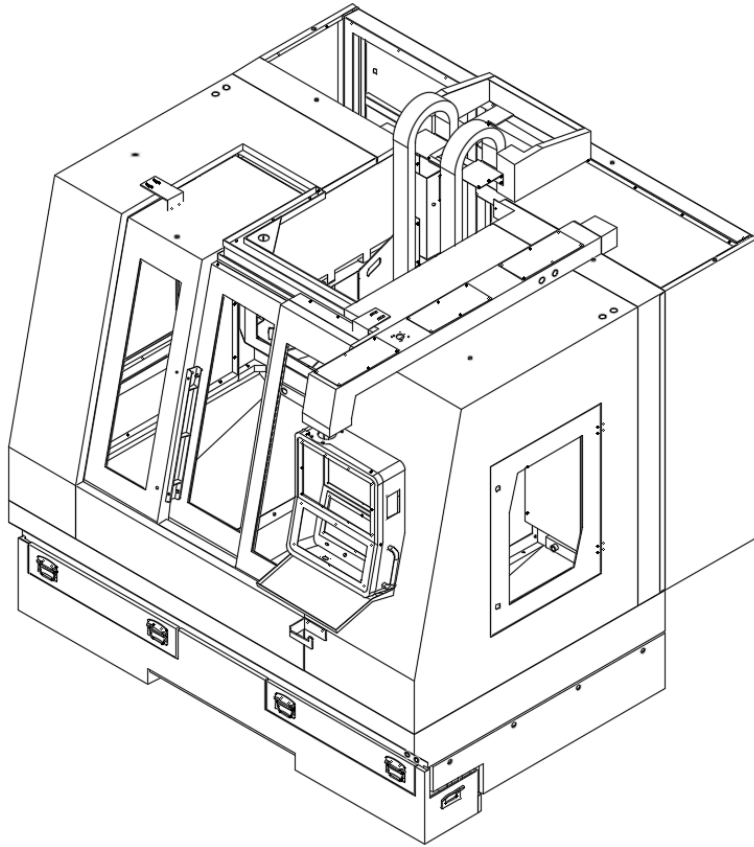



EZLearn

ASIA PACIFIC

EZLearn Machinery Ltd.

WEBSITE: <http://EZLearnCNC.com>

TEL: +886-3-553-2880

FAX: +886-3-553-2883

E-MAIL: sales@ezlearncnc.com.tw

ADDRESS: No. 166-5, Sec. 1, Huanbei Rd.
Zhubei City, Hsinchu County 302, Taiwan

NORTH AMERICA

DynaPath Systems Inc.

WEBSITE: <http://DynaPath.com>

TEL: +1 248-488-0440

FAX: +1 248-488-0430

E-MAIL: sales@dynapath.com

ADDRESS: 34155 Industrial Rd.
Livonia, MI 48150, USA

